

## SUPSI

Swiss BiPV Competence Centre

### Detail sheet

---

## Solar shadings

### 1600 PowerShade



<b>Product</b>	<b>1600PowerShade</b>
<b>Producer / CH supplier</b>	<b>Kawneer North America</b>
<b>Address</b>	<b>Kawneer North America Norcross GA 30092 USA</b>
<b>Contact</b>	<b>Tel: 770 745 1840 Fax: 770 745 6162 Mail : Web: <a href="http://www.kawneer.com">www.kawneer.com</a></b>

### Product specifics

Fixed sunshade for window or facade, composed of 3 aluminium boards, each covered with amorphous PV cells. In order to fit with various architectural and environmental requests, the orientation may be chosen during the assembling thanks to the different degrees of freedom. The whole system can move on the main axis and each board can be individually turned.

<b>Technology:</b>	<b>Multicrystalline</b>
<b>Power [W]:</b>	<b>75 per bay (25 per louver)</b>
<b>Size [mm] L, w, t:</b>	<b>Louver: 1400-2400 x 400</b>
<b>Specific power [W/m<sup>2</sup>]:</b>	<b>26-44</b>
<b>Price [CHF/m<sup>2</sup>]:</b>	<b>n.d.</b>
<b>Module weight [Kg]:</b>	<b>n.d.</b>
<b>Specific weight [Kg/m<sup>2</sup>]:</b>	<b>n.d.</b>
<b>Min. tilt:</b>	<b>n.d.</b>
<b>Custom made:</b>	<b>Color louver</b>
<b>Certifications:</b>	<b>n.d.</b>

## Product details

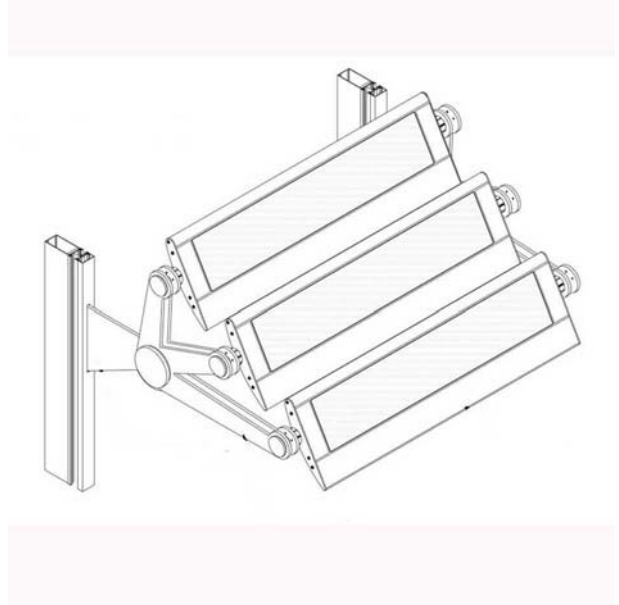

**LOUVER CROSS SECTION WITH PHOTOVOLTAIC PANEL**

